

HANDHELD LASER WELDING MACHINE

Up to 4x More Efficient | Truly Portable | Environmentally Friendly



 **WILKINSON STAR**

 **WELD STAR®**

MAX PHOTONICS

////

Smallest And lightest

The one and only TRULY
Portable System

With 18 years in the laser industry, Maxphotonics has 100% developed and brought to market the lightest and smallest handheld laser welding machine currently available in the world. Thanks to the advanced air cooling system which adapts phase change heat conduction technology, it weighs only **39KG** and the volume is **<0.1m³**.

There is also an integrated cable reel to store the feeder cable and make the machine more compact when being stored or transported.



Only 39kg

Volume <0.1m³

01

⋮





Product Specification

Nominal Power: **1500W**

Peak Power: **2500W**

Material	One-Sided Limit Welding Seam
Stainless steel	Up to 4.5mm
Mild steel	Up to 4.5mm
Galvanized sheet	Up to 4.0mm
Aluminum plate	Up to 4.0mm
Brass	Up to 3.0mm

Application Areas

- Maintenance and repair
- Metal processing by industry sheet metal
- Automotive OEM, furniture and white goods
- Construction, construction machinery, aviation, ship building, transportation

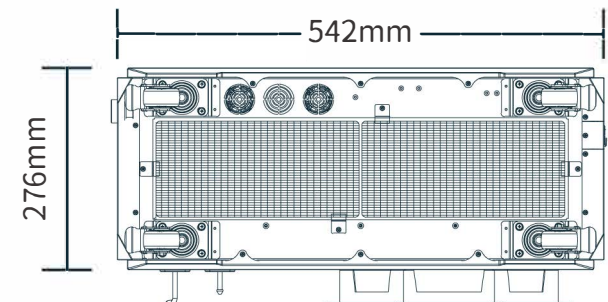
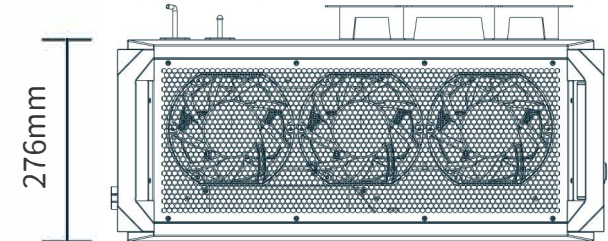
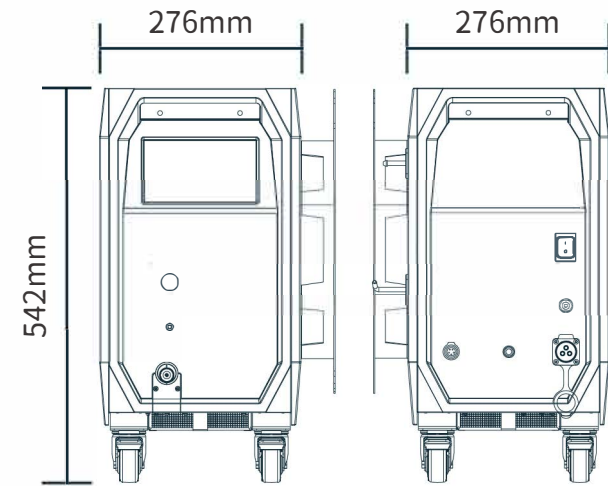
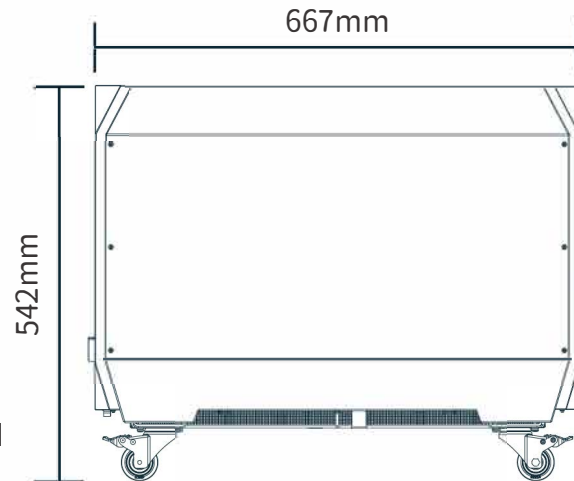
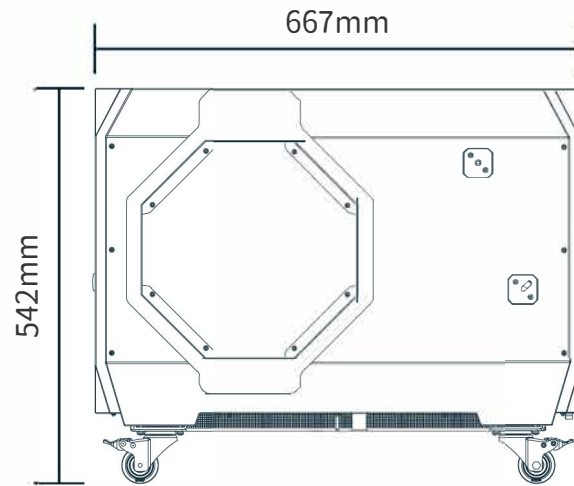

////

Excellent welding performance and energy efficiency

02

⋮

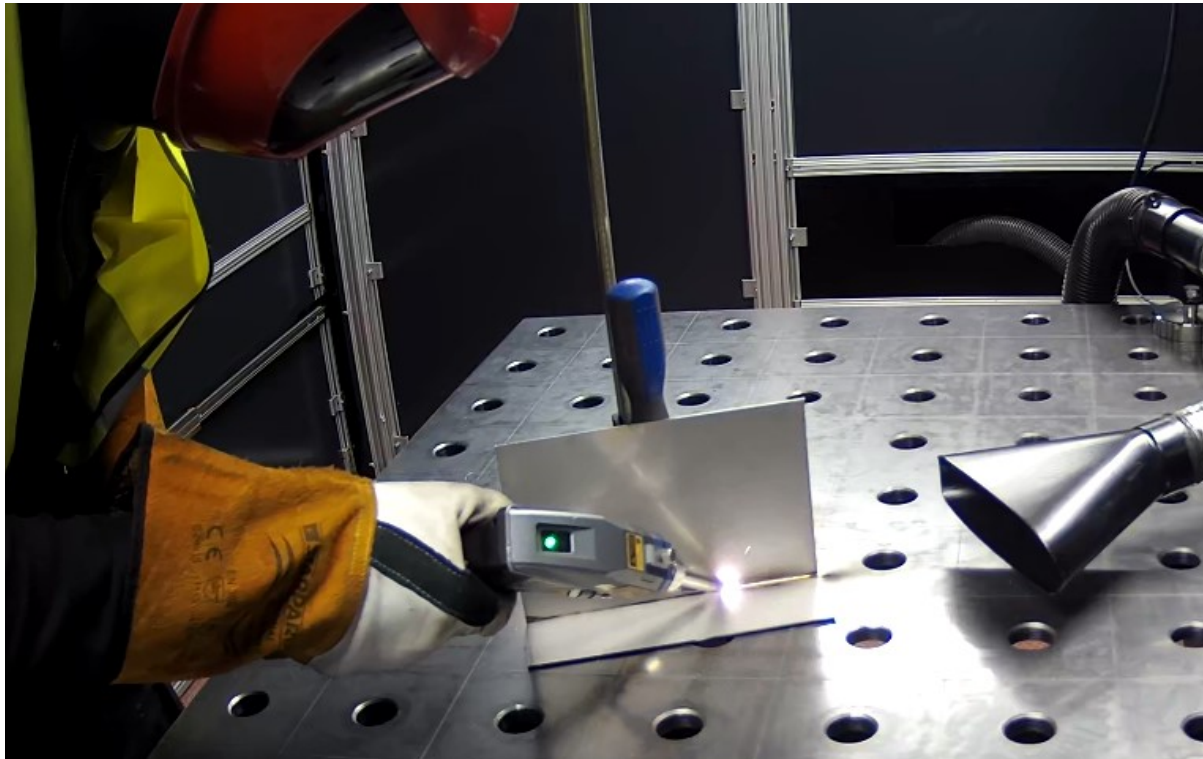

- **Up to 4 times** faster than traditional welding methods which helps our customers to **save 80% to 90% of electrical energy**, greatly improve production efficiency and reduce overall operational cost.
- State of the art laser control system brings high beam stability, consistent and neat welding seam, improved welding strength and minimum deformation.
- Cooling system adopts phase change heat conduction technology with powerful self-adaptive fans, which ensures long-term stability.



//// Application Materials

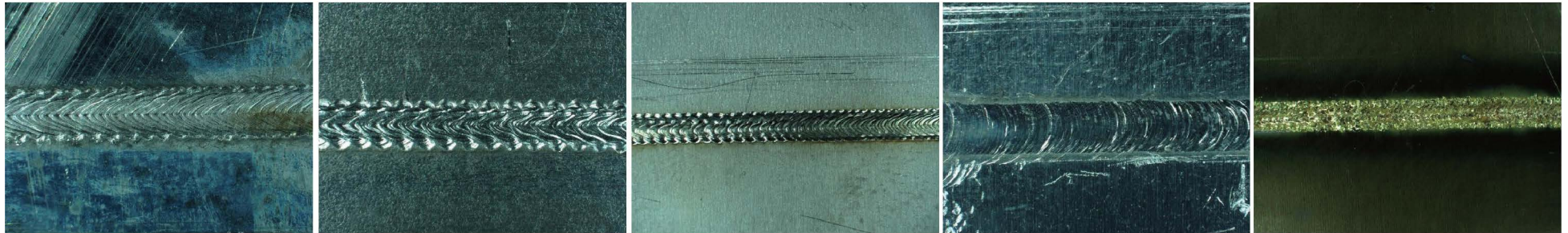

Galvanized

Carbon steel

Stainless steel

Aluminum

Copper

	Traditional welding method	Weld Star Handheld laser welding machine
Physical hazard	Arc radiation and smoke	Low radiation, environmentally friendly
Welding speed	Slow and inefficient	Up to 4 times faster than TIG and MIG
Welding quality	Welding seam is rough and irregular, need to be polished	Beautiful, perfect, neat welding seam, deep molten pool and high strength
Learning difficulty	High	Low
Heat affected zone	Large	Small
Bending deformation	High	Low
Welding seam damage	With air holes, easy to weld through	Uniform molten pool and good consistency
Welding materials	Limited by changes in consumables	Wide range of materials

////

The lightest and smallest handheld welding torch in the industry

03

⋮

The Weld Star handheld welding torch weighs **only 0.68kg**, is compact in size and has been ergonomically designed. It has been proven to be the most comfortable, stable, and easy-to-operate welding torch of its kind. In addition, multiple safety precautions allow for continuous and safe welding operations throughout the day.



////

Simple and easy to use

- Embedded with 24 pre-set modes for various materials
- Only 30 minutes training needed for beginners to operate the welding system
- Beginners can use the pre-set modes to achieve the same high quality, consistent and neat welding seams like experienced operators.
- Pre-set modes include wobble parameters, suitable for wider welding seams and high tolerance for workpiece assembly fit up.
- For advanced operators, additional process modes for different materials and thickness combinations can be created and stored.

04

7 inch
touch screen





Product parameters

Type	Parameters
Size	667mm*276mm*542mm
Weight	39kg
Volume	<0.1m ³
Wavelength (nm)	1080nm
Operating mode	Continuous and Pulsed
Output power	1500W
Input voltage	220VAC/50Hz/60Hz
Wobble	0-4mm
Wobble frequency	0-300Hz
Preset process parameters	32 groups
Average load power	6000W/4500W

Wire Feed Unit Specification

5/15 Kg - 0.6/0.8/1.0/1.2

Packing list

1	Handheld laser welding (including 5.6 meters fiber cable) / 1 set	10	Protective lens (φ20*3) /5 pieces
2	Welding torch/1	11	Lock ring wrench/1 pcs
3	Wire feeder (individually packaged) including wire feeding tube and wire feeding wheel/1 set	12	Wire nozzle assembly (0.8/1.0/1.2/1.6mm wire feed nozzle and wire feed frame)/1 set
4	Power cable (10 meters) / 1	13	Welding torch fixture (collimating focusing lens installation and removal)/1 set
5	Ground wire (10 meters) / 1	14	Cotton swabs 1 (25 pieces)/1 pack
6	Protective glasses (support 0D6+) / 3 pairs	15	Cotton swabs 2 (25 pieces)/1 pack
7	Hanging welding torch frame (including 4pcs hexagonal countersunk head screws)/1 set	16	Noise-isolating earplugs (Brand: 3M) / 5 pairs
8	Hanging armored cable frame (including 8pcs hexagonal countersunk head screws)/1 set	17	Dust mask (premium dust-proof) / 2 pairs
9	Nozzles (1, 3, A, B and flat nozzles) / 2 sets	18	Screwdriver (hexagon socket) / 1 pcs



50 A family business
engineered through
generations since 1971



WELD STAR

Exclusive Distributor UK & Ireland

Contact Details

Tom Smith

0161 728 7901

07834 177518

tom.smith@wilkinsonstar.com

Wilkinson Star Ltd, Shield Drive,
Wardley Industrial Estate, Worsley,
Manchester, M28 2WD

0161 793 8127

wilkinsonstar247.com

**Demonstrations are available at our
Manchester Training Academy**
Contact Tom to Book



Hand Held Laser Welding Enclosure - 3m x 2m

Specifically designed for use with the new generation of handheld laser welders, and complies to IEC 60825-4 standards.

- Integrates with the built in safety systems of your laser welding equipment.
- Compact 3.1m X 2.1m Footprint—Perfect for processing small fabrications and components.
- 1.3m sliding door, with integrated labyrinth flash seals to prevent accidental viewing of laser radiation.
- Fully integrated “plug and play” electronics including door interlock, power distribution, cable trunking and LED lighting.
- Modular design, allowing for interchangeable positions and future expansion capabilities.

